

## PP MK2 Foam Pump Proportioner

### Features

- Designed to meet the proportioning requirements of EN 13565-1:2003+A1:2007 Chapter 7 and NFPA 16:2015 Chapter 4
- FM Approved for use with SKUM AFFF 3% UG and SKUM ARC 3x3 UG Foam Concentrates
- Less total system hardware and maintenance required with minimal moving parts and no electrical hook-up required
- Manufactured using corrosion resistant design and materials
- Wafer type water connection
- Flanged or screw threaded BSP foam connection

### Description

SKUM PP MK2 proportioning systems function by maintaining equal pressures in the foam concentrate and water inlets to the proportioner. This balancing ability allows the proportioner to be used over a wide range of flows and pressures. The system will also respond quickly and accurately to changes in the water inlet pressures and flow rates.

The system utilizes a positive displacement foam pump to pressurize foam concentrate within the supply manifold. A pressure control valve, located in the return line to the foam concentrate storage tank, is set to maintain a regulate pressure in the supply manifold at a minimum of 1 bar (14.5 psi) to 2 bar (29 psi) higher than the maximum pressure in the water supply line. Foam concentrate, not required by the proportioner, returns to the atmospheric storage tank through the pressure control valve.

Each proportioner consists of a cast bronze body, metering orifice, bronze pressure balancing valve, and pressure sensing tubing.

The proportioner is available in six standard sizes ranging from DN50 to DN250 with flows ranging from 125 Lpm (33 gpm) to 37,850 Lpm (10,000 gpm) and is designed to fit between two DIN PN16 (ANSI Class 150) pipe flanges. A minimum of five pipe diameters of straight pipe is necessary upstream and three pipe diameters downstream of the proportioner.



PP-150  
010277

### Application

The proportioner is part of an in-line balanced proportioning system using an atmospheric foam concentrate tank connected to a positive displacement foam concentrate pump. It is designed to automatically proportion and control the mixing of the foam concentrate into a water stream when the system flow and pressure are within the operating range of the unit.

Typical applications include monitor and deluge foam pump systems.

### Approvals and Listings

The SKUM PP MK2 Proportioner is designed in accordance with EN 13565-1:2003 Chapter 7 and NFPA 16:2015 Chapter 4. The proportioner is approved, qualified under, or meets the requirements of the following specifications:

- FM Approvals – FM 5130
  - The SKUM PP MK2 Proportioner is FM Approved for use with SKUM AFFF 3% UG and SKUM ARC 3x3 UG
- Det Norske Veritas (DNV)
- China National Test Centre Approval (TFRI)
  - PP-100 and PP-150 models only
- Russian State Fire Academy
- Russian Maritime Register of Shipping (RMRS)



**Note:** SKUM PP MK2 proportioners are only FM Approved when used in conjunction with the specific foam concentrates and equipment shown in the Approval Guide available at [www.ApprovalGuide.com](http://www.ApprovalGuide.com).

## Ordering Information

Specify part number, size, and foam proportioning percent when order is placed.

Part Number	Description	Foam Agent	Approvals
123005118	PP-50, BSP	SKUM AFFF 3% UG	FM
123005125	PP-50, BSP	SKUM ARC 3X3 UG	FM
123005111	PP-50, BSP	1%-6%	-
123008115	PP-80, BSP,	SKUM AFFF 3% UG	FM
123008122	PP-80, BSP	SKUM ARC 3X3 UG	FM
123008108	PP-80, BSP	1%-6%	-
123310109	PP-100, DIN/ANSI Flange	SKUM AFFF 3% UG	FM
123310116	PP-100, DIN/ANSI Flange	SKUM ARC 3X3 UG	FM
123310102A	PP-100, DIN/ANSI Flange	3%	-
123310102E	PP-100, DIN/ANSI Flange	2%	-
123310102B	PP-100, DIN/ANSI Flange	1%	-
123310102J	PP-100, DIN/ANSI Flange	6%	-
123315112	PP-150, DIN/ANSI Flange	SKUM AFFF 3% UG	FM
123315119	PP-150, DIN/ANSI Flange	SKUM ARC 3X3 UG	FM
123315105A	PP-150, DIN/ANSI Flange	3%	-
123315105E	PP-150, DIN/ANSI Flange	2%	-
123315105B	PP-150, DIN/ANSI Flange	1%	-
123315105J	PP-150, DIN/ANSI Flange	6%	-

Part Number	Description	Foam Agent	Approvals
123320214	PP-200, DIN Flange	SKUM AFFF 3% UG	FM
123320221	PP-200, DIN Flange	SKUM ARC 3X3 UG	FM
123320103A	PP-200, DIN Flange	3%	-
123320103E	PP-200, DIN Flange	2%	-
123320103B	PP-200, DIN Flange	1%	-
123320103J	PP-200, DIN Flange	6%	-
123320228	PP-200, ANSI Flange	SKUM AFFF 3% UG	FM
123320235	PP-200, ANSI Flange	SKUM ARC 3X3 UG	FM
123320207A	PP-200, ANSI Flange	3%	-
123320207E	PP-200, ANSI Flange	2%	-
123320207B	PP-200, ANSI Flange	1%	-
123320207J	PP-200, ANSI Flange	6%	-
123325104A	PP-250, DIN Flange	3%	-
123325104E	PP-250, DIN Flange	2%	-
123325104B	PP-250, DIN Flange	1%	-
123325104J	PP-250, DIN Flange	6%	-
123325206A	PP-250, ANSI Flange	3%	-
123325206E	PP-250, ANSI Flange	2%	-
123325206B	PP-250, ANSI Flange	1%	-
123325206J	PP-250, ANSI Flange	6%	-

## Proportioner Information

Model	Connection*		A		B		Weight		Max. Working Pressure	
	Foam	Water	mm	(in.)	mm	(in.)	kg	(lb)	bar	(psi)
PP-50	3/4 in. BSP (Female)	DN 50 / 2 in. Flange	200	(7.9)	37	(1.5)	5	(11.0)	16	(232.1)
PP-80	3/4 in. BSP (Female)	DN 50 / 2 in. Flange	200	(7.9)	37	(1.5)	10	(22.0)	16	(232.1)
PP-100	DN 50 / 2 in. Flange	DN 100 / 4 in. Flange	312	(12.3)	62	(2.4)	18	(39.7)	16	(232.1)
PP-150	DN 50 / 2 in. Flange	DN 150 / 6 in. Flange	333	(13.1)	62	(2.4)	21	(46.3)	16	(232.1)
PP-200	DN 80 / 3 in. Flange	DN 200 / 8 in. Flange	411	(16.2)	82	(3.2)	43	(94.8)	16	(232.1)
PP-250	DN 80 / 3 in. Flange	DN 250 / 10 in. Flange	439	(17.3)	82	(3.2)	53	(116.8)	16	(232.1)

\*Flange connections to fit DIN PN16 or ANSI Class 150

### PP-50 / PP-80

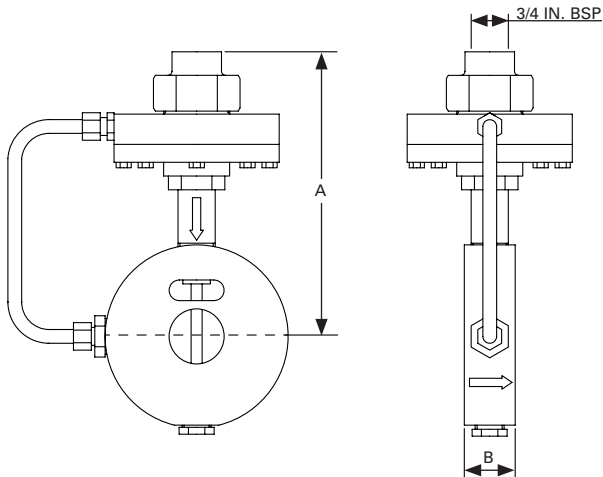

010278

### PP-100 / PP-250

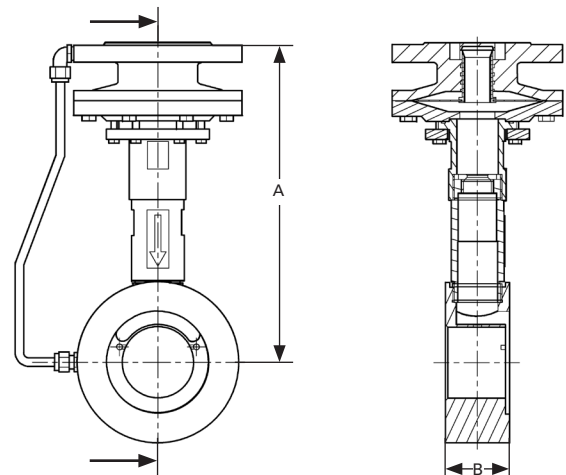

010280

### PP-200 / PP-250

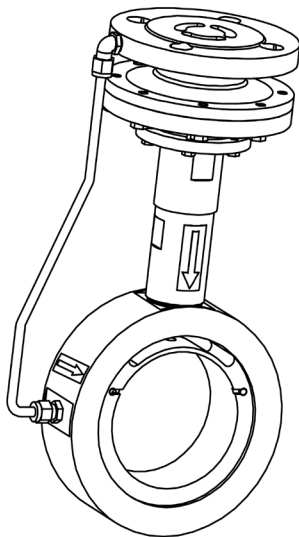

010279

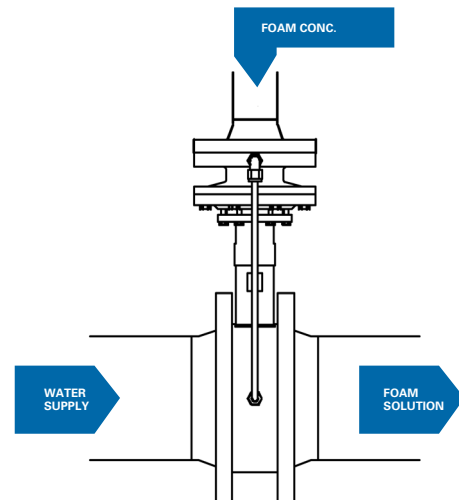

010281

## System Specifications

Model	Foam Agent	Minimum Capacity		Maximum Capacity	
		Lpm	(gpm)	Lpm	(gpm)
PP-50	1% to 6%	125	(33)	800	(211)
PP-80	1% to 6%	300	(79)	2,000	(528)
PP-100	1% to 6%	770	(203)	6,100	(1,612)
PP-150	1% to 6%	1,500	(396)	18,000	(4,756)
PP-200	1% to 6%	2,875	(760)	26,500	(7,000)
PP-250	1% to 6%	5,100	(1,347)	37,850	(10,000)

**Note:** Refer to the FM Approval Guide for concentrate-specific flow rates.

## SKUM PP MK2 Friction Loss

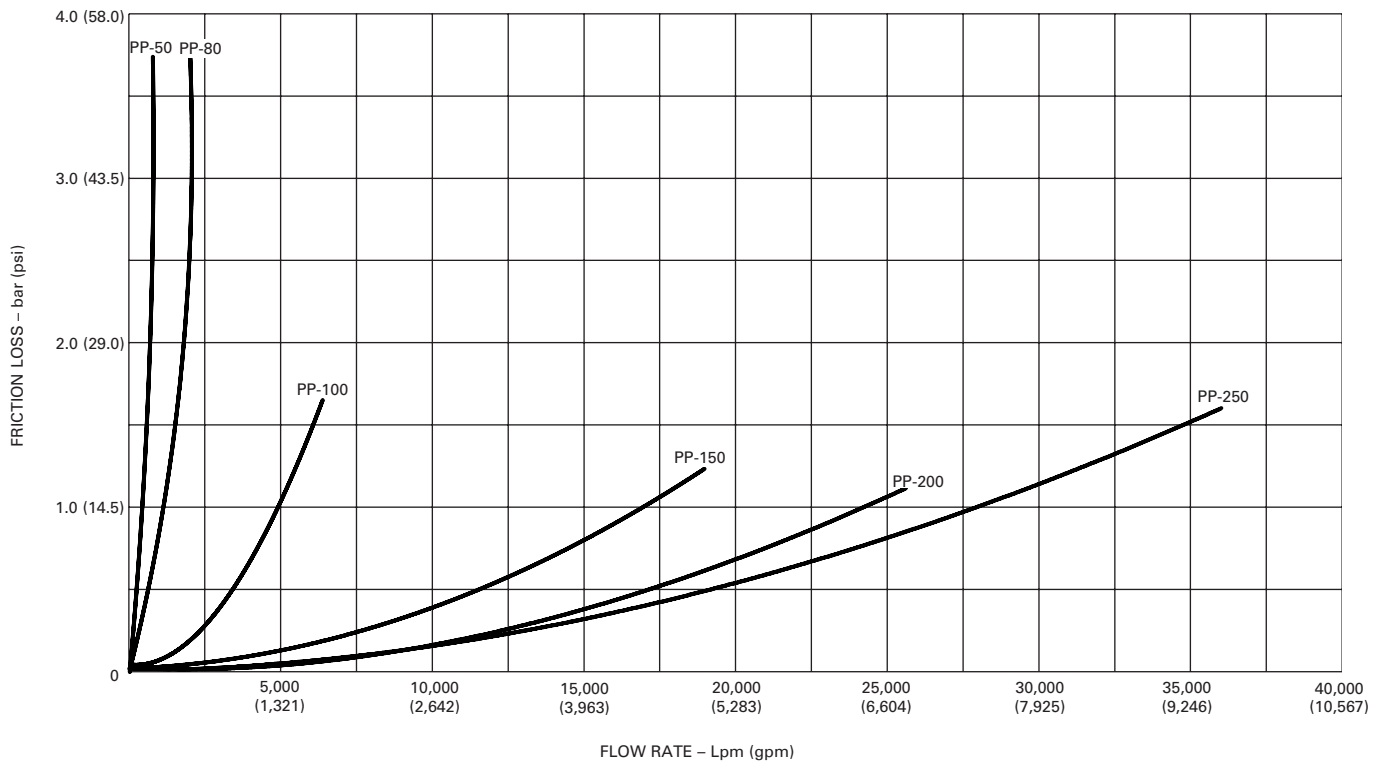

010282

**Note:** The converted values in this document are provided for dimensional reference only and do not reflect an actual measurement. SKUM and the product names listed in this material are marks and/or registered marks. Unauthorized use is strictly prohibited.