

TP MK2 Bladder Tank Proportioner

Features

- Designed to meet the proportioning requirements of EN 13565-1:2003+A1:2007 Chapter 7 and NFPA 16:2015 Chapter 4
- FM Approved for use with SKUM AFFF 3% UG and SKUM ARC 3x3 UG Foam Concentrates
- Allows the use of lower cost bladder tank foam-water sprinkler systems
- Less total system hardware and maintenance required with minimal moving parts and no electrical hook-up required
- Manufactured using corrosion resistant design and materials
- Wafer type water connection

Description

SKUM TP MK2 proportioning systems function by metering foam concentrate into the water supply line. Upon system actuation, incoming water applies pressure to the concentrate in the bladder, which supplies pressurized concentrate to the proportioning device. The foam-water solution is then piped to the discharge devices in the hazard area.

Each proportioner consists of a cast bronze body and metering orifice. The proportioner is available in six standard sizes ranging from DN50 to DN250 with flows ranging from 125 Lpm to 34,100 Lpm (33 gpm to 9,008 gpm) and is designed to fit between two DIN PN16 (ANSI Class 150) pipe flanges. A minimum of five pipe diameters of straight pipe is necessary upstream and three pipe diameters downstream of the proportioner.

Application

The SKUM TP MK2 Proportioner is FM Approved for use with SKUM AFFF 3% UG and SKUM ARC 3x3 UG Foam Concentrates. Refer to the Systems Specifications on page four for other SKUM foam concentrates that have been tested for use with this proportioner.

The proportioner is designed for use with bladder tank systems only. It may be installed up to 10.7 m (35.1 ft) equivalent length from the bladder tank. The normal swing check, concentrate isolation, and hydraulic valve(s) do not have to be included in this equivalent length calculation.

The SKUM TP MK2 proportioner is designed to proportion and control the mixing of the foam concentrate into a water stream when the system flow and pressure are within the operating range of the unit.

Typical applications include fire monitor and deluge bladder tank systems.



TP-200
010287

Approvals and Listings

The SKUM TP MK2 Proportioner is designed in accordance with EN 13565-1:2003 Chapter 7 and NFPA 16:2015 Chapter 4. The proportioner is approved, qualified under, or meets the requirements of the following specifications:

- FM Approvals – FM 5130
 - The SKUM TP MK2 Proportioner is FM Approved for use with SKUM AFFF 3% UG and SKUM ARC 3x3 UG
- Det Norske Veritas (DNV)
- China National Test Centre Approval (TFRI)
 - TP-100 models only
- Russian State Fire Academy
- Russian Maritime Register of Shipping (RMRS)



Note: SKUM TP MK2 proportioners are only FM Approved when used in conjunction with the specific foam concentrates and equipment shown in the Approval Guide available at www.ApprovalGuide.com.

Ordering Information

Specify part number, size, and foam proportioning percent when order is placed.

Part Number	Description	Foam Agent	Approvals
124005112	TP-50, BSP	SKUM AFFF 3% UG	FM
124005119	TP-50, BSP	SKUM ARC 3X3 UG	FM
124005105	TP-50, BSP	1%-6%	-
124008114	TP-80, BSP,	SKUM AFFF 3% UG	FM
124008121	TP-80, BSP	SKUM ARC 3X3 UG	FM
124008107	TP-80, BSP	1%-6%	-
124310011	TP-100, BSP (Female) and Groove	SKUM AFFF 3% UG	FM
124310018	TP-100, BSP (Female) and Groove	SKUM ARC 3X3 UG	FM
124310004A	TP-100, BSP (Female) and Groove	3%	-
124310004E	TP-100, BSP (Female) and Groove	2%	-
124310004B	TP-100, BSP (Female) and Groove	1%	-
124310004J	TP-100, BSP (Female) and Groove	6%	-
124315014	TP-150, BSP (Female) and Groove	SKUM AFFF 3% UG	FM
124315021	TP-150, BSP (Female) and Groove	SKUM ARC 3X3 UG	FM
124315007A	TP-150, BSP (Female) and Groove	3%	-
124315007E	TP-150, BSP (Female) and Groove	2%	-
124315007B	TP-150, BSP (Female) and Groove	1%	-
124315007J	TP-150, BSP (Female) and Groove	6%	-

Part Number	Description	Foam Agent	Approvals
124320110	TP-200, DIN/ANSI Flange	SKUM AFFF 3% UG	FM
124320117	TP-200, DIN/ANSI Flange	SKUM ARC 3X3 UG	FM
124320103A	TP-200, DIN/ANSI Flange	3%	-
124320103E	TP-200, DIN/ANSI Flange	2%	-
124320103B	TP-200, DIN/ANSI Flange	1%	-
124320103J	TP-200, DIN/ANSI Flange	6%	-
124325104A	TP-250, DIN Flange	3%	-
124325104E	TP-250, DIN Flange	2%	-
124325104B	TP-250, DIN Flange	1%	-
124325104J	TP-250, DIN Flange	6%	-
124325206A	TP-250, ANSI Flange	3%	-
124325206E	TP-250, ANSI Flange	2%	-
124325206B	TP-250, ANSI Flange	1%	-
124325206J	TP-250, ANSI Flange	6%	-

Proportioner Information

Model	Connection*		A		B		Weight		Max. Working Pressure	
	Foam	Water	mm	(in.)	mm	(in.)	kg	(lb)	bar	(psi)
TP-50	3/4 in. BSP (Female)	DN 50 / 2 in. Flange	125	(4.9)	37	(1.5)	6	(13.2)	16	(232.1)
TP-80	3/4 in. BSP (Female)	DN 50 / 2 in. Flange	140	(5.5)	37	(1.5)	10	(22.0)	16	(232.1)
TP-100	1 1/2 in. BSP (Female) and DN 50 / 2 in. Groove	DN 100 / 4 in. Flange	239	(9.4)	62	(2.4)	12	(26.5)	16	(232.1)
TP-150	1 1/2 in. BSP (Female) and DN 50 / 2 in. Groove	DN 150 / 6 in. Flange	262	(10.3)	62	(2.4)	15	(33.1)	16	(232.1)
TP-200	DN 80 / 3 in. Flange	DN 200 / 8 in. Flange	337	(13.3)	72	(2.8)	32	(70.5)	16	(232.1)
TP-250	DN 80 / 3 in. Flange	DN 250 / 10 in. Flange	365	(14.4)	72	(2.8)	42	(92.6)	16	(232.1)

*Flange connections to fit DIN PN 16 or ANSI Class 150

TP-50 / TP-80

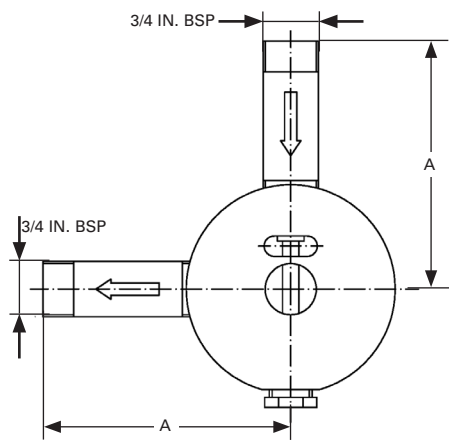

010284

TP-100 / TP-150

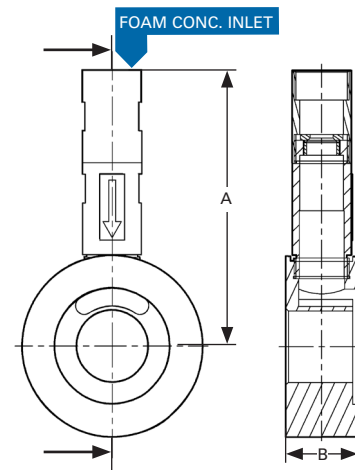

010283

TP-200 / TP-250

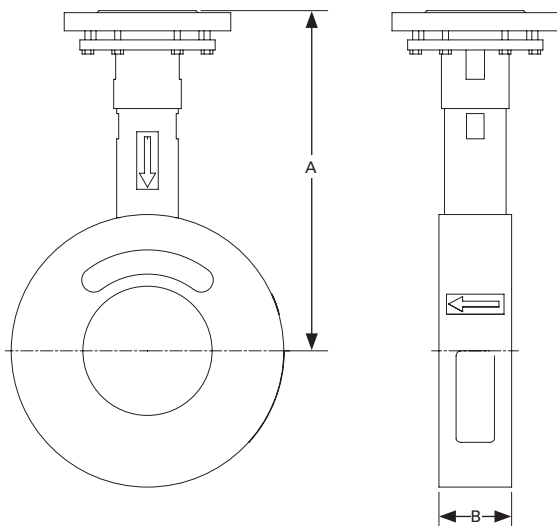

010285

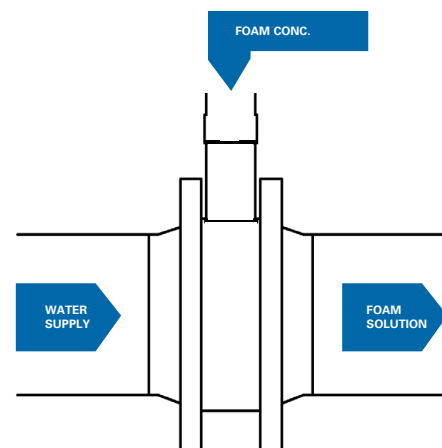

010281

System Specifications

Model	Foam Agent	Minimum Capacity		Maximum Capacity		Proportioner K Factor
		Lpm	(gpm)	Lpm	(gpm)	
TP-50	1% to 6%	125	(33)	800	(211)	450
TP-80	1% to 6%	300	(79)	2,000	(528)	1,110
TP-100	1% to 6%	770	(203)	6,100	(1,612)	3,180
TP-150	1% to 6%	1,500	(396)	18,000	(4,756)	6,040
TP-200	1% to 6%	2,875	(760)	26,500	(7,000)	17,340
TP-250	1% to 6%	5,100	(1,347)	34,100	(10,000)	25,775

Note: Refer to the FM Approval Guide for concentrate-specific flow rates.

SKUM PP MK2 Friction Loss

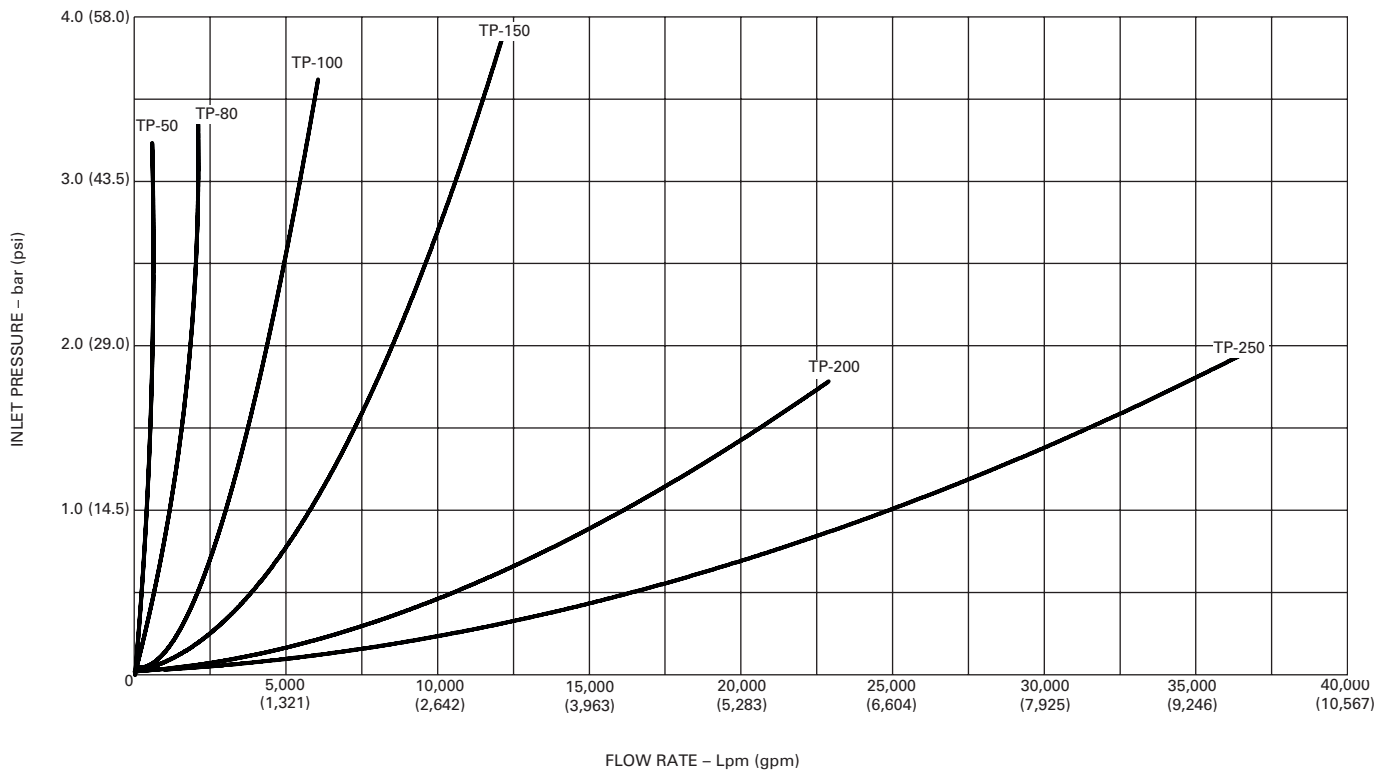

010286

Note: The converted values in this document are provided for dimensional reference only and do not reflect an actual measurement.

SKUM and the product names listed in this material are marks and/or registered marks. Unauthorized use is strictly prohibited.