

FJM-MAN Manual Fog/Jet Monitor

Description

- A range of manually operated fog/jet, water, and foam monitors with exceptional flow characteristics that optimise throw range.
- Exceptional delivery of water or foam as a jet or as a spray pattern.
- The FJM-MAN Manual Fog/Jet Monitor range is available for a number of alternate mounting positions.
- FJM and the FJM-S options available. The FJM-S monitor has an inbuilt foam concentrate inductor, eliminating the need for a separate proportioning system.

Application

The FJM range of fog/jet monitors are designed for easy operation and reliability. Its lighter construction materials ensure an overall light weight.

FJM monitors have a wide operating range and are site adjustable to any demands of the local environment, while still maintaining the highest level of performance.

Note: When running any of the FJM-S range of monitors, adjust to nominal capacity for accurate proportioning.

Features

- Wide capacity range
- Adjustable flow
- Compact and balanced design
- Low weight
- Easily manoeuvred due to low friction bearings
- Long throw length
- Adjustable stream pattern
- Corrosion resistant construction of stainless steel and bronze

Connections

- Foam/water inlet: flanged according to DIN PN 16, JIS 10K, or ANSI 150 lb

Optional Components

- Built-in inductor optional on all models (S Version)
- Gear operation; optional for FJM-150, standard for FJM-200
- Suction hose and valve



Listings and Approvals

- Det Norske Veritas DNV
- Bureau Veritas
- Russian Maritime Register of Shipping (RMRS)
- EN 13565-1 Only sizes 80 and 100 (CNBOP)

Ordering Information

Please specify the following:

1. Part number
2. Type
3. Flange type
4. Capacity: flow and pressure
5. Foam induction (S-version)

Ordering Information

Part No.	Description
■ 161008407	FJM-80 DIN/ANSI
■ 161008319	FJM-80 JIS
■ 161008340	FJM-80 S DIN/ANSI, excluding suction hose
■ 161008537	FJM-80 S JIS, excluding suction hose
■ 160208305	FJM 80 ANSI
■ 161008423	FJM-80 S ANSI, excluding suction hose
■ 161008618	FJM-80 suction hose 1 1/4 in. 3 m
■ 161010403	FJM-100 DIN/ANSI
■ 161010216	FJM-100 JIS
■ 161010315	FJM-100 S DIN/ANSI, excluding suction hose
■ 161010417	FJM-100 ANSI
■ 161010329	FJM-100 S ANSI, excluding suction hose
■ 16101606	FJM-100 suction hose 2 in. 3 m
■ 161015304	FJM-150 DIN/ANSI/JIS
■ 161015405	FJM-150 S DIN/ANSI, excluding suction hose
■ 161315317	FJM-150 G DIN/ANSI/JIS
■ 161315338	FJM-150 S G DIN/ANSI/JIS, excluding suction hose
■ 161015608	FJM-150 suction hose 2 in. 3 m
■ 161320127	FJM-200 G DIN
■ 161320229	FJM-200 G ANSI
■ 162020260	FJM-200 S G ANSI, excluding suction hose
■ 161320236	FJM-200 G JIS
■ 162020267	FJM-200 S G JIS, excluding suction hose
■ 161020618	FJM-200 suction hose 2.5 in. 3 m

FJM Monitors - Capacity Ranges

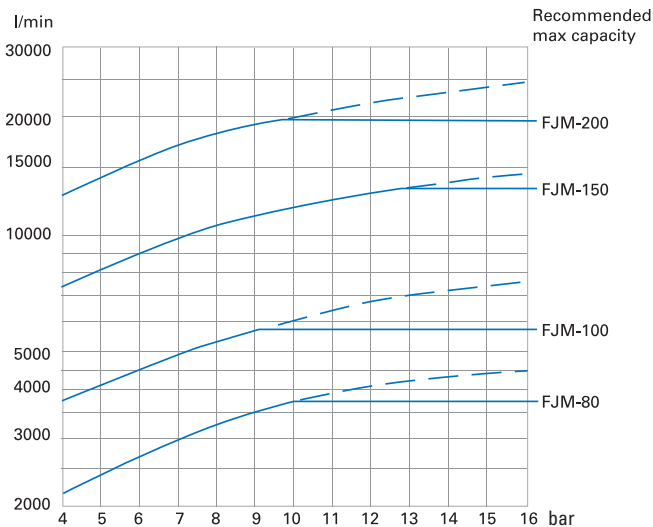

FJM-80

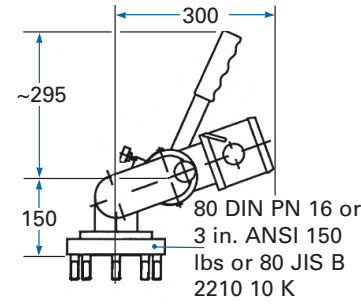

FJM-80 S

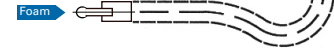
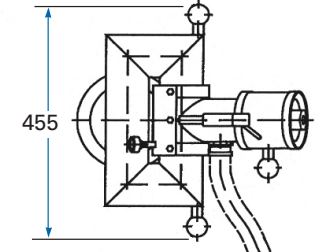
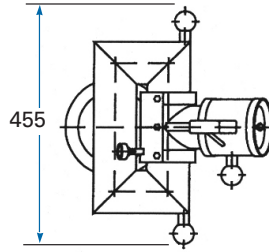
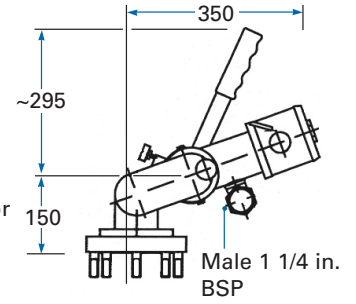

FJM-80 Monitor - Range of Jet

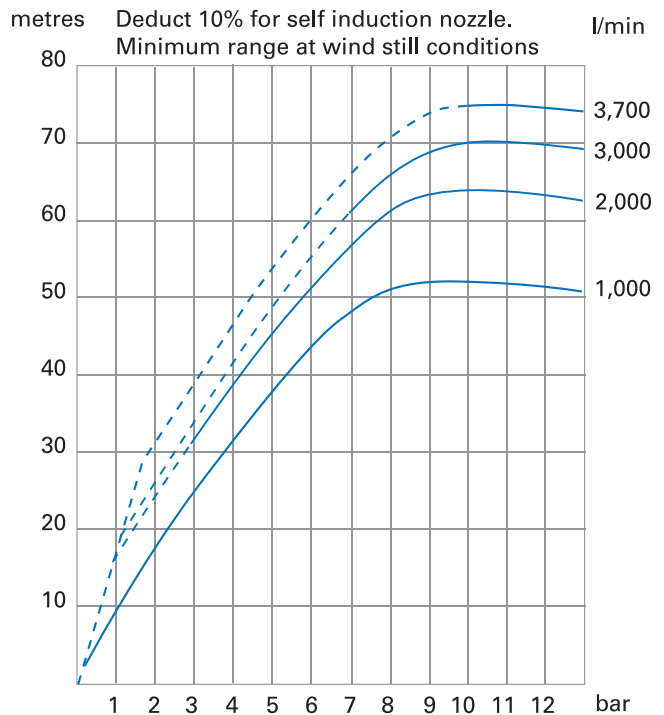

$$\text{Reaction force (N)} = 0.233 \times Q \text{ (Lpm)} \times \sqrt{p \text{ (bar)}}$$

Note: Achieving the values listed in the range of jet graph depends on the monitor's elevation angle. For further details, see the length-height relationship graph.

FJM-100

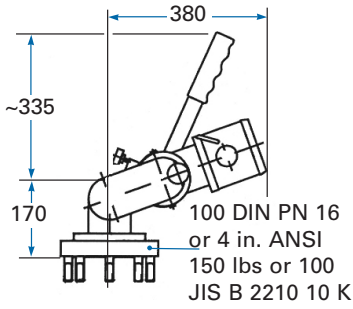

FJM-100 S

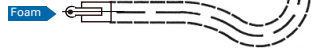
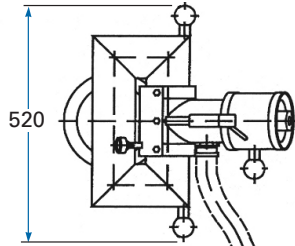
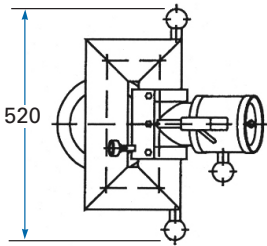
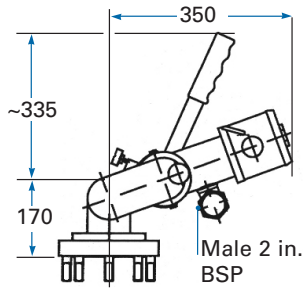

FJM-150

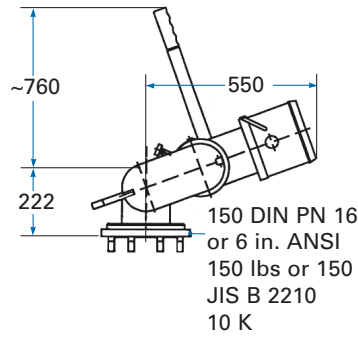

FJM-150 S

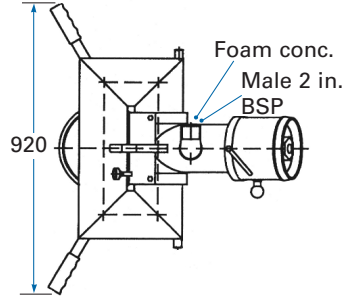
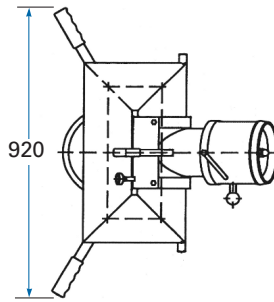
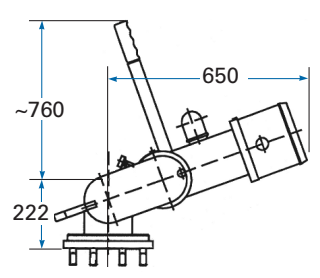

FJM-100 Monitor - Range of Jet

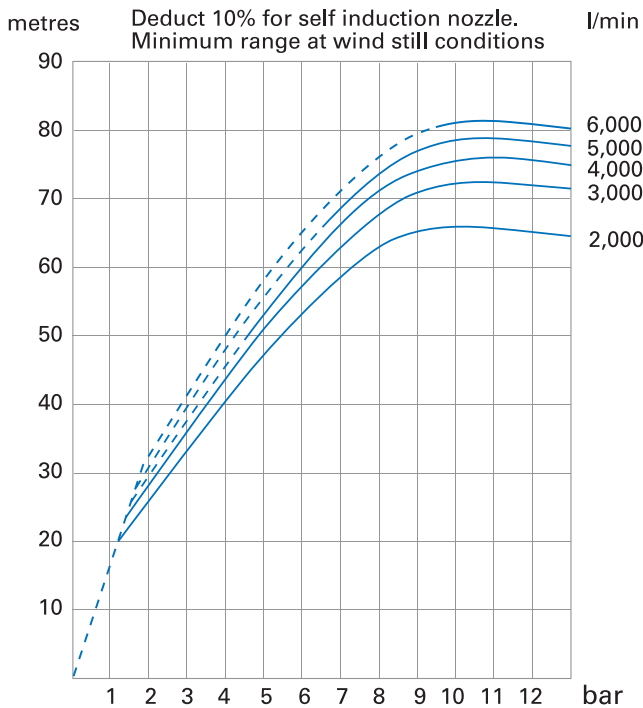

Reaction force (N) = 0.233 x Q (Lpm) x √p (bar)

Note: Achieving the values listed in the range of jet graph depends on the monitor's elevation angle. For further details, see the length-height relationship graph.

FJM-150 Monitor - Range of Jet

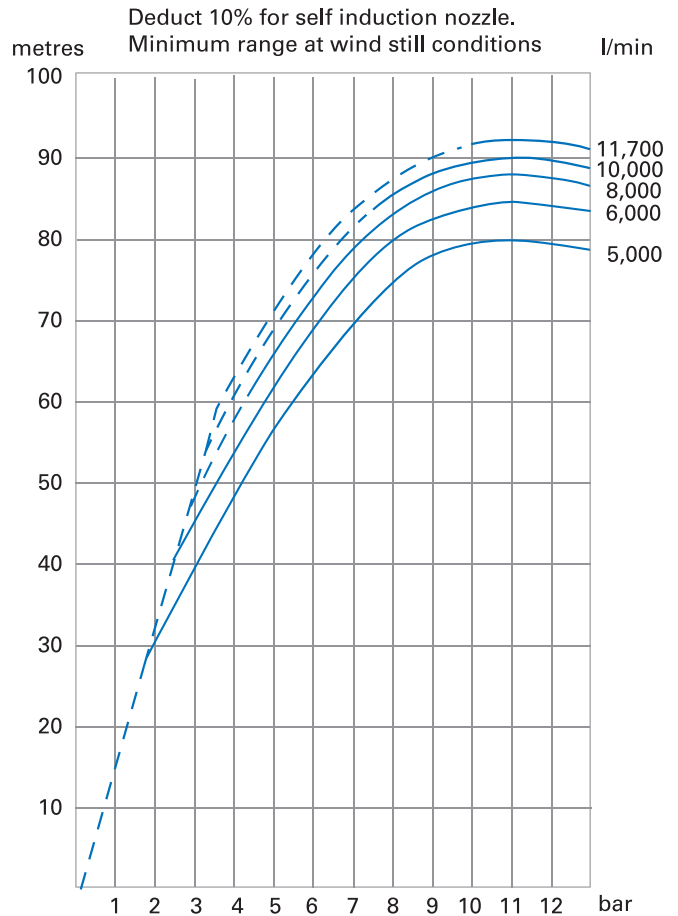

Reaction force (N) = 0.233 x Q (Lpm) x √p (bar)

Note: Achieving the values listed in the range of jet graph depends on the monitor's elevation angle. For further details, see the length-height relationship graph.

FJM-150 G

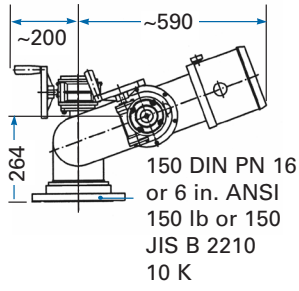

FJM-150 SG

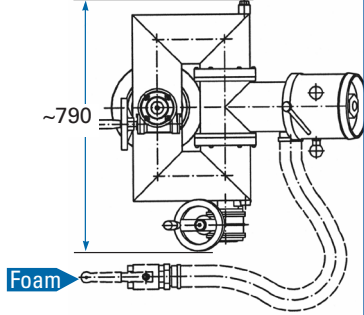
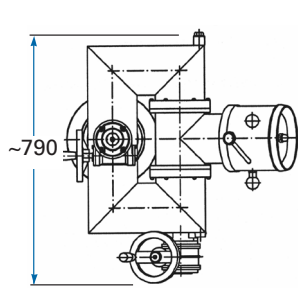
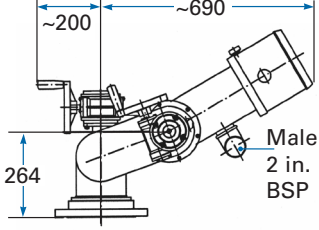

FJM-200 G

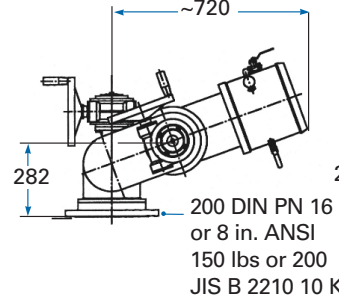

FJM-200 SG

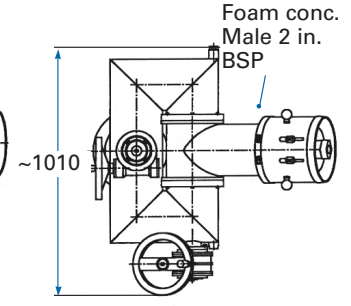
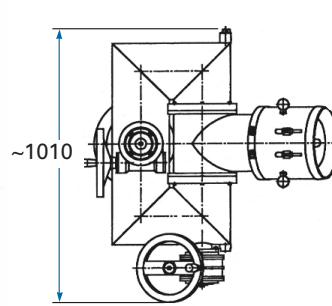
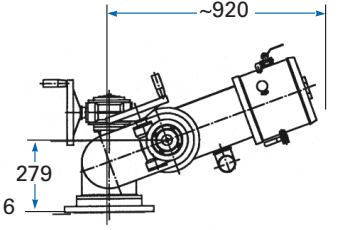

FJM-200 Monitor - Range of Jet

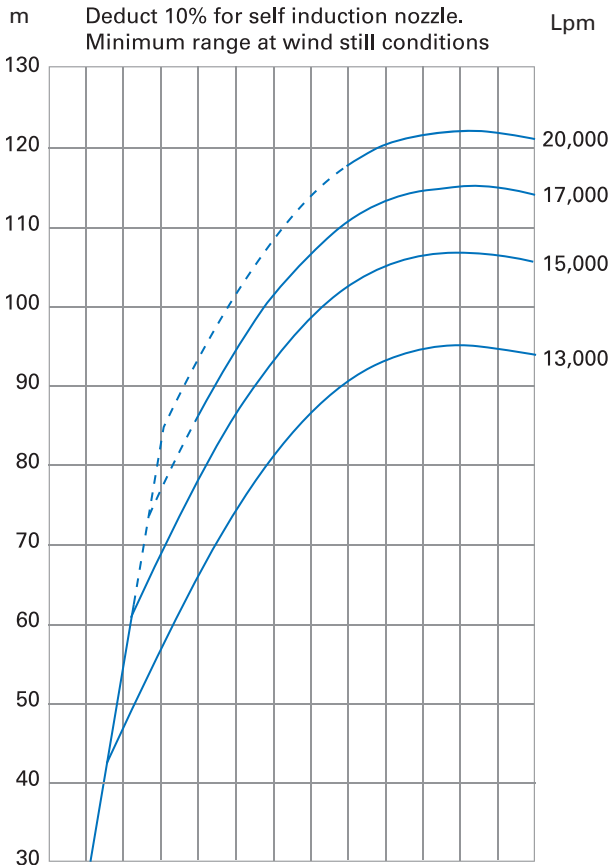

$$\text{Reaction force (N)} = 0.233 \times Q \text{ (Lpm)} \times \sqrt{p \text{ (bar)}}$$

Note: Achieving the values listed in the range of jet graph depends on the monitor's elevation angle. For further details, see the length-height relationship graph.

Length - Height Relationship

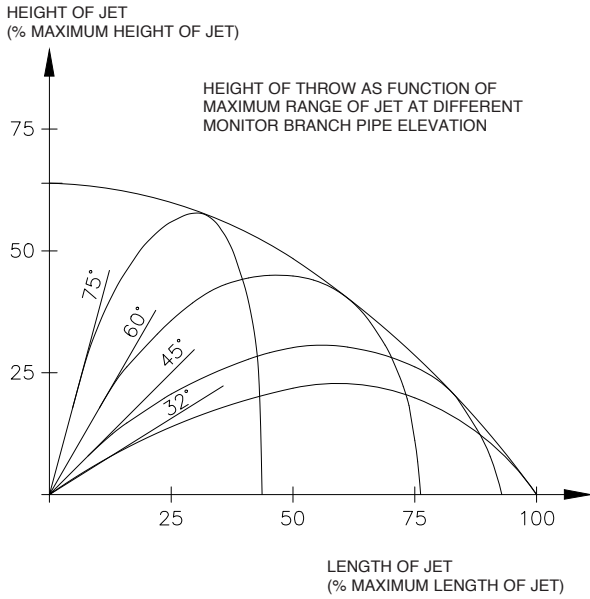

$$\text{Reaction force (N)} = 0.233 \times Q \text{ (Lpm)} \times \sqrt{p \text{ (bar)}}$$

FJM Monitors - Average Fog Pattern in Still Air

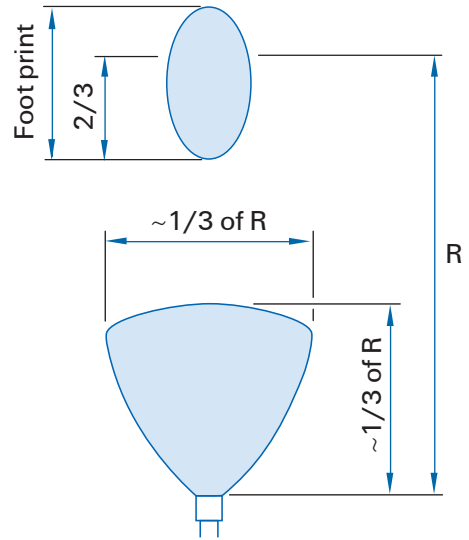

Performance Data

FJM series standard	80	100	150	200
Water capacity	Max. 3,700 Lpm Min. 500 Lpm	Max. 6,000 Lpm Min. 1,000 Lpm	Max. 11,700 Lpm Min. 3,000 Lpm	Max. 20,000 Lpm Min. 8,000 Lpm
Design pressure	4-16 bar optimum 10-12 bar	4-16 bar optimum 10-12 bar	4-16 bar optimum 10-12 bar	4-13 bar optimum 10-12 bar
Rotation	360°	360°	360°	360°
Elevation	-60° / +90°	-60° / +90°	-60° / +70°	-60° / +70°
Connection flange	Stud bolt	Stud bolt	Open hole	Open hole
Weight	14 kg	22 kg	57 kg	90 kg
FJM series built-in inductor	80	100	150	200
Water capacity	Max. 3,700 Lpm Min. 500 Lpm	Max. 6,000 Lpm Min. 1,000 Lpm	Max. 11,700 Lpm Min. 3,000 Lpm	Max. 20,000 Lpm Min. 8,000 Lpm
Design pressure	4-16 bar optimum 10-12 bar	4-16 bar optimum 10-12 bar	4-16 bar optimum 10-12 bar	4-13 bar optimum 10-12 bar
Foam capacity	170 Lpm	320 Lpm	600 Lpm	600 Lpm
Elevation	-45° / +90°	-45° / +90°	-45° / +70°	-45° / +70°
Suction connection	1 1/4 in. BSP male	2 in. BSP male	2 in. BSP male	2 in. BSP male
Weight	15 kg	24 kg	60 kg	93 kg

SKUM, and the product names listed in this material are marks and/or registered marks. Unauthorised use is strictly prohibited.